

ER COLLET STANDARD DIN 6499

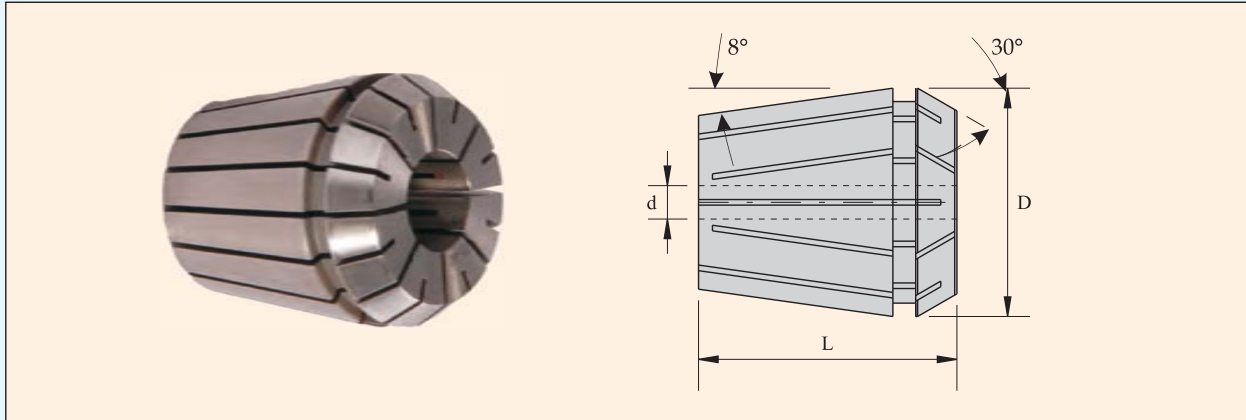

Collet Designation	Bore Range 'd'			Clamping Capacity per set		Each Collet collapse by mm	D mm	L mm
	From mm	To	in steps mm	From mm	To mm			
ER8	0.5	5	0.5	0.5	5.0	0.5	8.5	13.5
ER11	0.5	7	0.5	0.5	7.0	0.5	11.5	18.0
ER16	0.5	10	1.0	0.5	10.0	1.0	17.0	27.0
ER20	1.0	13	1.0	1.0	13.0	1.0	21.0	31.0
ER25	1.0	16	1.0	1.0	16.0	1.0	26.0	35.0
ER32	2.0	20	1.0	2.0	20.0	1.0	33.0	40.0
ER40	3.0	26	1.0	3.0	26.0	1.0	41.0	46.0
ER50	10.0	34	2.0	10.0	34.0	2.0	52.0	60.0

The collet must always be inserted into the nut before setting the tool into the collet. The collet is fitted inside the nut by applying slight pressure A. It is removed by applying B to the collet. Never tighten the chuck without a correct size tool shank being present in the collet.

